

DL 2632 SWITCHING LOGIC

Logic circuit for switching the trigger pulse switch in 4-quadrant converter systems. The switching logic measures the polarity of the torque and switches the trigger pulses to the corresponding converter after a current-free delay time.

Technical features:

Input X_n for torque comparator (speed set point value).

Input X_i for current comparator with adjustable LIMIT threshold.

Output S_A and S_B for the corresponding inputs of the trigger pulse switch DL 2631 with led indication of the active converter.

Output INV for the corresponding inverting input of the absolute value generator DL 2623.

Output INH for the corresponding inhibit input of the two pulse control unit DL 2616, with adjustable delay time from 10 ms to 2 s and led indication of the commutating time.

Current comparator output C for EXT selection input of the active elements of the adaptive PI controller DL 2624.

Power supply: +15 V / 0 V / -15 V

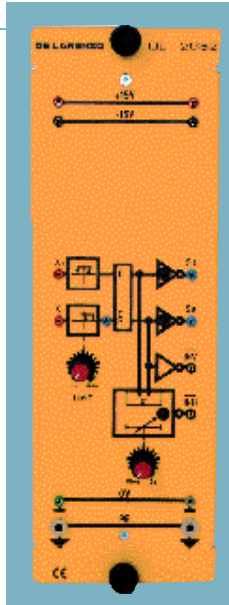

DL 2633 FUNCTION GENERATOR

Versatile function generator.

Technical features:

Functions: sine/triangle/square wave/square wave with variable duty cycle.

Frequency range:

10 Hz . . . 100 kHz in 4 decades.

Output voltage:

0 V to 20 V_{pp} adjustable

Two additional outputs with attenuator: -20 dB / -40 dB

TTL output for triggering.

VCO input, AC coupled.

Power supply:

single-phase from mains

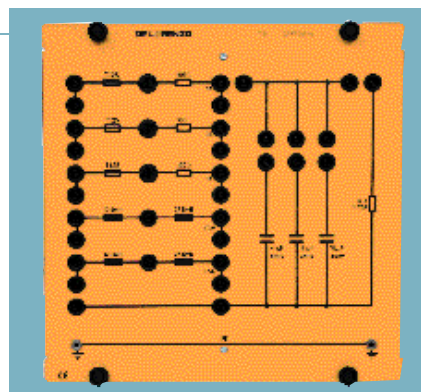
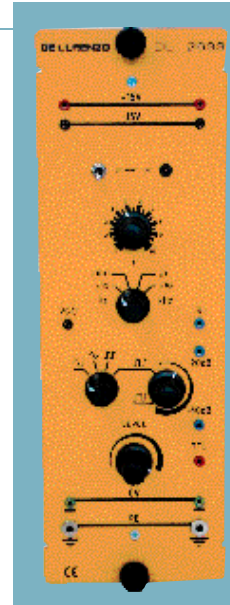

DL 2635 LOAD

Ohmic, inductive and capacitive load suitable for the experiments in the power electronics laboratory.

Technical features:

a) Load resistors: 3 x 100 Ω / 1 A

Protection with fuses: 3 x T1.25 A

Possibility of connecting in series (300 Ω), in parallel (33.33 Ω) or in star and delta.

b) Load inductors: 2 x (12.5 - 50) mH / 2.5 A

Possibility of connecting in series (100 mH) and in parallel (6.25 mH).

c) Load capacitors: 4-8-16 μ F / 450 Vac

Possibility of connecting in parallel (28 μ F).

Discharge resistor: 1 k Ω / 0.22 A

DL 2634 VOLTAGE DIVIDER

20:1

Electronic voltage divider used as an interface between the dc machines (200 V) and the automatic control circuits (-10 V . . . +15 V).

Possibility of capacitive filter with time constant 0.1 s.

Protection against overvoltages up to 1000 Vdc.

Power supply:

+15 V / 0 V / -15 V

