

# DL 3155BI01 TRANSDUCERS

This block deals with biomedical sensors and transducers. The classification criterion that has been used in this course for the sensors and the transducers is based on their physical operation principle. Resistive, optical or photoelectrical sensors and transducers, used in the temperature data and optical signals acquisition, are studied in this board.

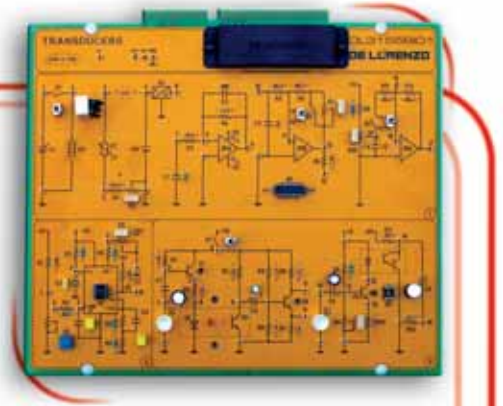

## CIRCUIT BLOCKS

- Temperature sensors
- °C/°F converter
- U/f transducer
- Photodiode
- Phototransistor
- Optocoupler

## THEORETICAL TOPIC COVERAGE

- The bio-engineering and the biomedical instrumentation
- Biomedical signals
- Measurement systems of biomedical signals
- Characteristics of the transducers
- The temperature sensors
- The optical and opto-electronic sensors



# THE BOARDS propaedeutic modules

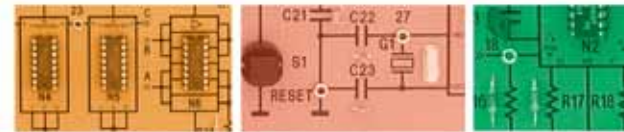

# DL 3155BI02 AMPLIFIERS

The electrical signal, generated by sensors, is usually at a low level of amplitude and power, so that it is necessary to amplify it before its transfer, further analogue or digital processing and visualization. In this course we will study the characteristics of the pre-amplifiers and amplifiers for the processing of biomedical signals.

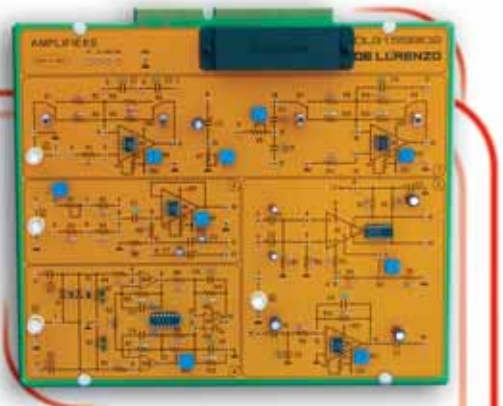

## CIRCUIT BLOCKS

- Inverting and non inverting configuration of an OP. AMP. at low and high voltage gain
- Differential Amplifier: differential gain and frequency function
- Study of the input and output impedances
- Pre-amplifiers
- Differential amplifier for the instrumentation

## THEORETICAL TOPIC COVERAGE

- Amplification of biomedical signals
- The ideal operational amplifiers
- The real operational amplifiers
- Preamplifier and main amplifier
- Evaluation of the CMRR